

HOW TO PREPARE A PALLET SHIPMENT
IN LTL TRANSPORTATION?

- » Place the parcel on an **undamaged EURO UIC, EPAL pallet, or other carrier** suitable for mechanical handling*.

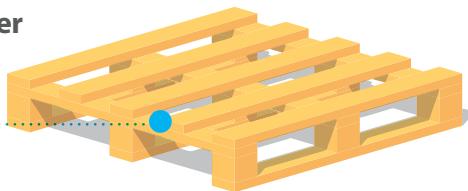

- ⚠ **REMEMBER!** The elements of the parcel must not protrude beyond the pallet outline.

* The possibility of transshipment by both forklift and manual pallet truck. The strength of the pallet should correspond to the type of loaded goods.

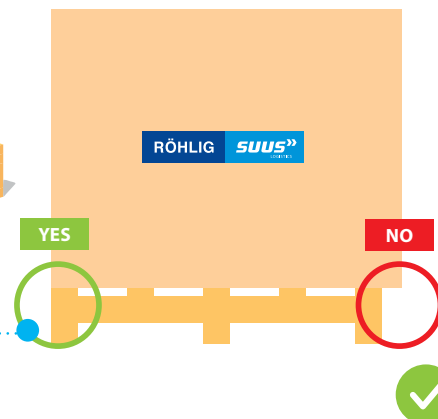

- » Stack **from heaviest to lightest**, stacking **from the bottom to the top**.

- ⚠ **REMEMBER!** The finished transport unit must not exceed:

- 4 m in length
- 2,2 m in height
- 1,2 m in width
- 1500 kg in weight**

**the maximum dynamic load capacity for a given carrier type cannot be exceeded.

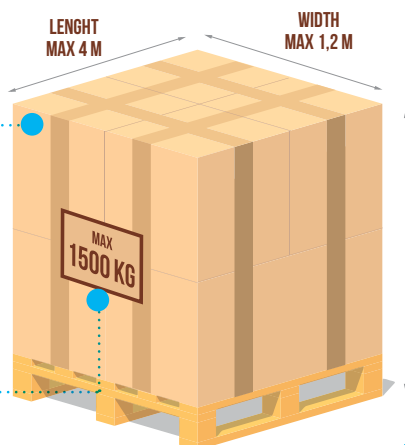

- » **Secure the goods firmly** to the pallet. Use **heavy-duty straps** for this.

- » **Secure the corners** of the parcel using card board or Styrofoam protection.

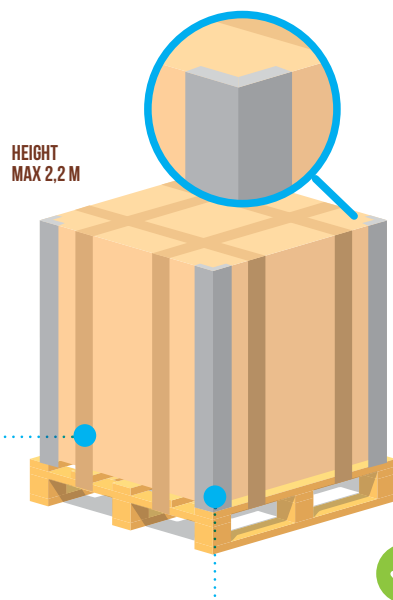

- » Secure the parcel by **wrapping it in three layers on all sides with stretch film and branded tape**, to prevent access to the contents.

- ⚠ **REMEMBER!** Never stick labels on top of the parcel.

- » Apply an **address label SUUS** on the **long side** of the parcel and place information on the handling requirements (e.g. 'handle with care'!).

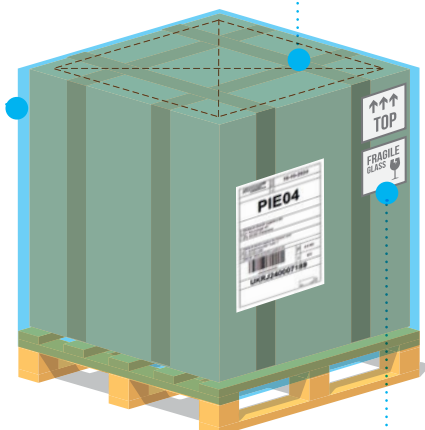

- ⚠ **REMEMBER!** Tall and narrow parcels should be placed on a carrier that ensures stability.

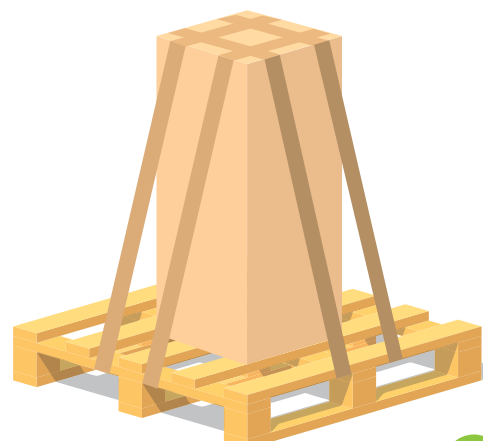

HOW TO PREPARE A PALLET SHIPMENT IN LTL TRANSPORTATION?

- » For bulk bags stacked on pallets, **put a cardboard divider on the bottom (before stacking the bags)** and secure it around the parcels bottom.

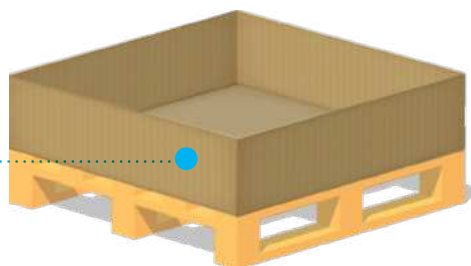

- » Then, wrap the entire parcel with foil and plastic strap.

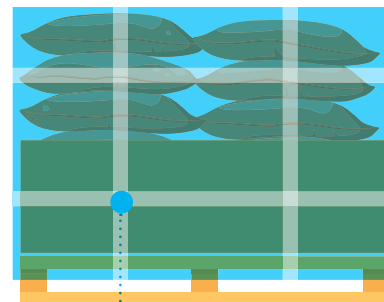

RISK OF AMPERING WITH CONTENT

Sample cargo type: loose, bagged

- ❌ No protection of the stack of bags from the top, allowing access to the contents.

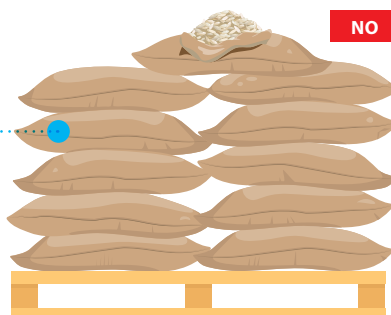

- ✅ The goods on the carrier must be secured in such a way as to completely prevent access to their contents.

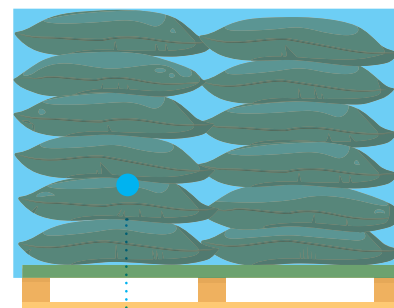

- » Place parcels protruding beyond the pallet, such as metal sheets, boards, etc., on the carrier **and secure the load with plastic strap on all sides** to immobilise it.

- » Secure all **protruding sides of the parcel with cardboard corners**, or – if shipping metal sheets – with wooden corners.

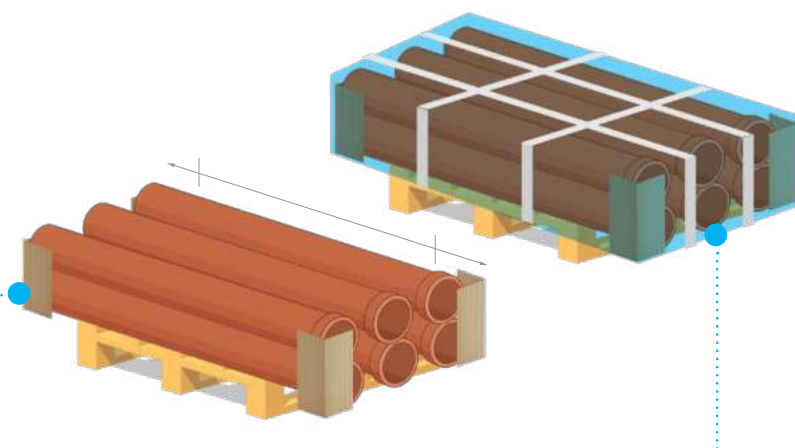

- » Wrap the parcel with foil and heavy-duty straps.

HOW TO PREPARE A PARCEL IN A CARDBOARD BOX IN LTL TRANSPORTATION?

- » **Match the strength of the packaging to the weight** and shape of the contents so that manual handling is possible.
- » **Adjust the size of the package to the contents of the parcel,** to avoid empty spaces.
- » **Fill in the empty spaces with filler,** to minimize the risk of damage to the parcel.
- » **Use baffles and fillers inside the package.** Pad the bottom and sides with bubble wrap and/or shaped Styrofoam.

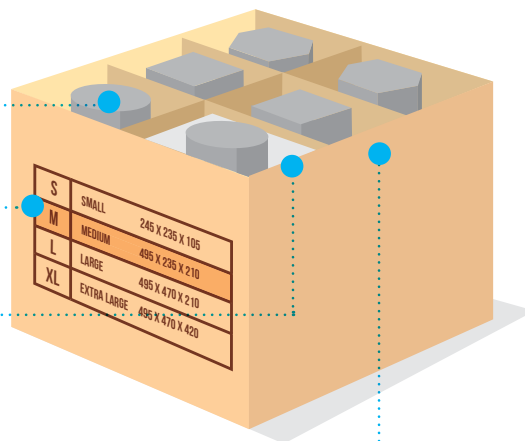

- » Tape the parcel with branded tape to prevent access to the contents. Preferably, wrap so as to form the **letter H** at the top and base of the package.
- » Place the **address label** on the **side of the package.** Label the parcel with appropriate warning pictograms.
- » Place a **'HEAVY'** label on the side of the package if parcel weight is more than **20 kg.**

⚠ REMEMBER! A transport unit ready for carriage must not exceed **50 kg in weight*** (If it is heavier than 50 kg, then it must be on the carrier).

* excluding household appliances with the possibility of transport on a specialised cart with a maximum weight of up to 168 kg.

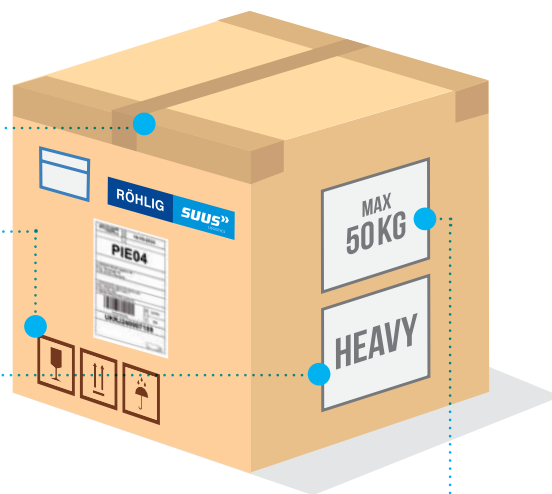

- » If the parcel contains **more than 5 boxes,** then it must be packed on the carrier in accordance with the rules for packing a pallet shipment.

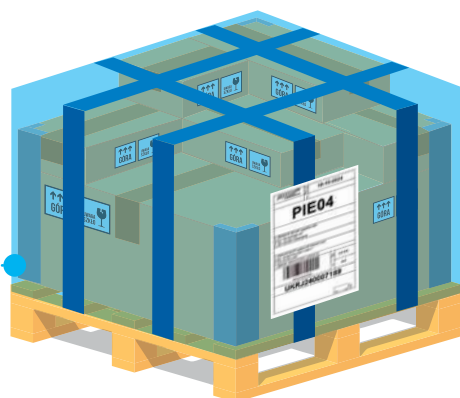

HOW TO PREPARE A ROLLED PARCEL IN LTL TRANSPORTATION?

- » **Secure the ends** of the parcel/ roll with cardboard or other abrasion-resistant material.
- » For weight over **50 kg**, it must enable manual handling with a special **mandrel**.
- » Secure the parcel by **wrapping it** several times **on all sides with stretch film and protect it with branded tape**.

⚠ **REMEMBER!** The transport-ready unit must not exceed **6 meters in length**. Put a **'HEAVY'** label on the package **if the roll weights more than 20 kg**.

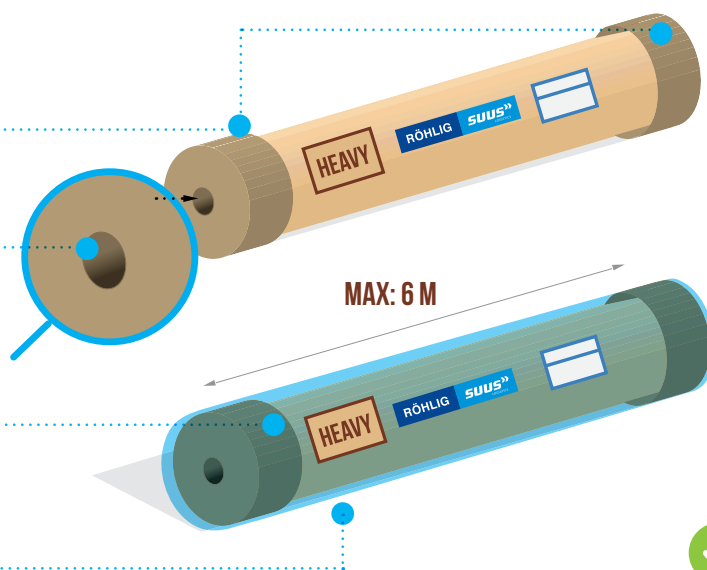

- » If the parcel contains more **than 5 rolls**, it must be packed on the carrier in accordance with the rules for packing a pallet shipment.

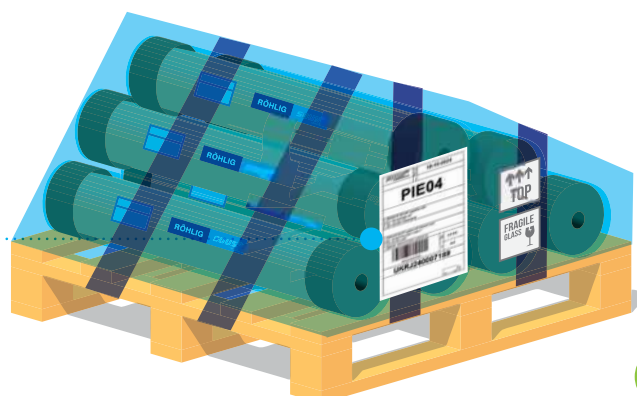

- » Rolls placed vertically on a pallet **must not extend beyond its edges**. Use vertical banding tapes, to secure the goods on the pallet, and horizontal ones that will further stabilize the load.

- » On the top layer put cardboard cap. Wrap the entire shipment with stretch wrap or shrink film.

- » Merchandise bundled with each other.

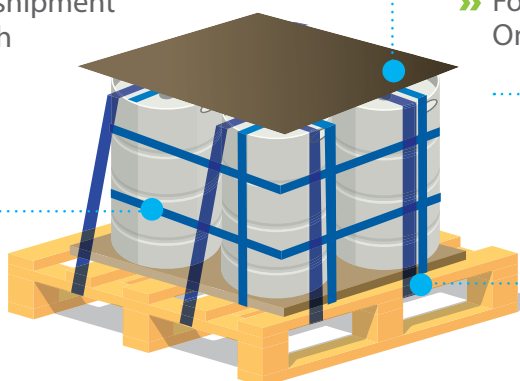

- » Cardboard caps.

- » Foil overlaps On the pallet.

- » Merchandise bundled to a pallet.

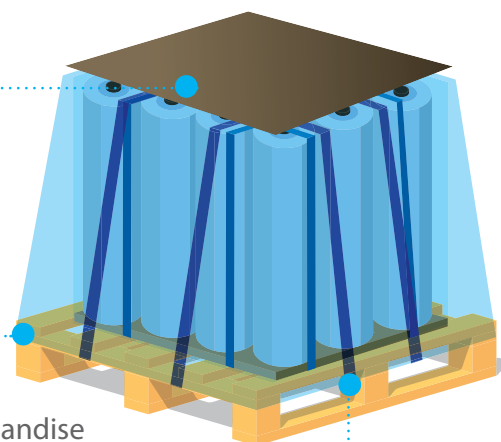

- ✘ Placement of a **BIG BAG** shipment directly on the pallet does not adequately secure it for transport.

- ✔ Big Bags, place the parcel on a pallet, secure the bottom with a cardboard divider.

Next, secure the parcel to the carrier using, for example, a tie strap to prevent it from moving.

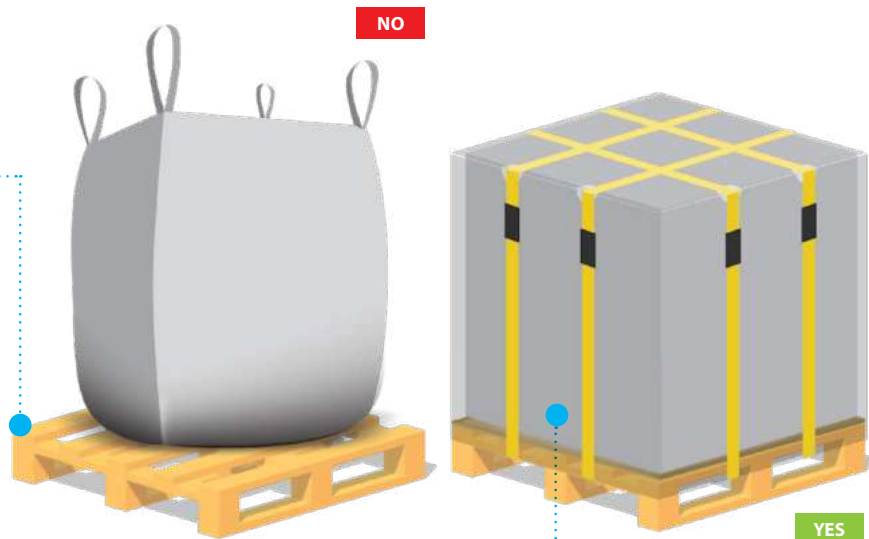

FAILURE TO SECURE FRAGILE OBJECTS

Sample of cargo type: gypsum garden figure

- ✘ Fastening with plastic strap to the carrier. Wrapping with stretch film **DOES NOT PROTECT** this type of goods from damage.

- ✔ Sensitive goods should be placed in a wooden crate or cardboard box and protected with polystyrene or foam profiles and marked with warning pictograms.

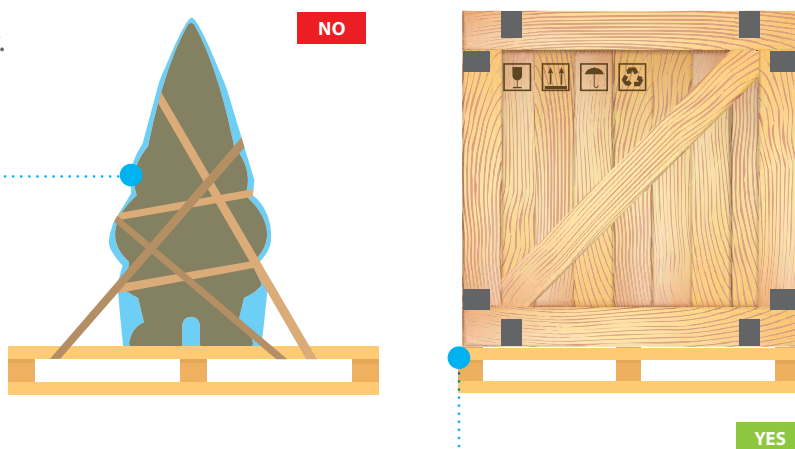

RISK OF DAMAGE BY GOODS PROTRUDING BEYOND THE PALLET OUTLINE

Sample cargo type: motorcycle

- ✘ Goods protruding beyond the pallet outline may damage other parcels.

- ✔ Such goods should be placed on a carrier that fits their size and should be properly secured.

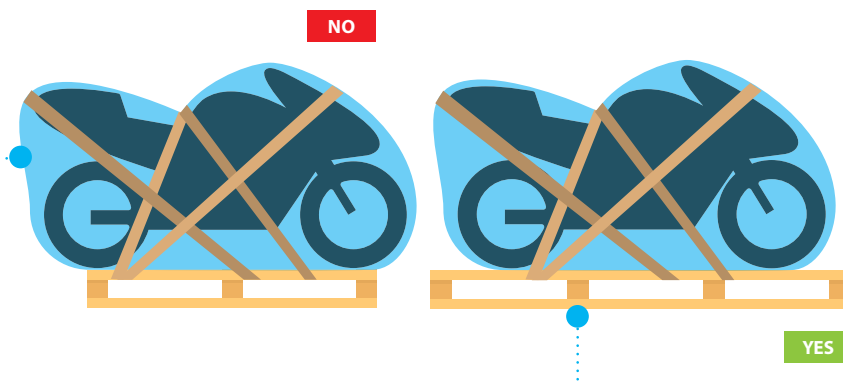

Risk of damage to shipment by stacking

✘ Stacking the parcel may damage it!

✔ Mark the side of the parcel with a shipping label with an additional 'no stacking' label; mark the top of the parcel with a cone or another 'no stacking' label.

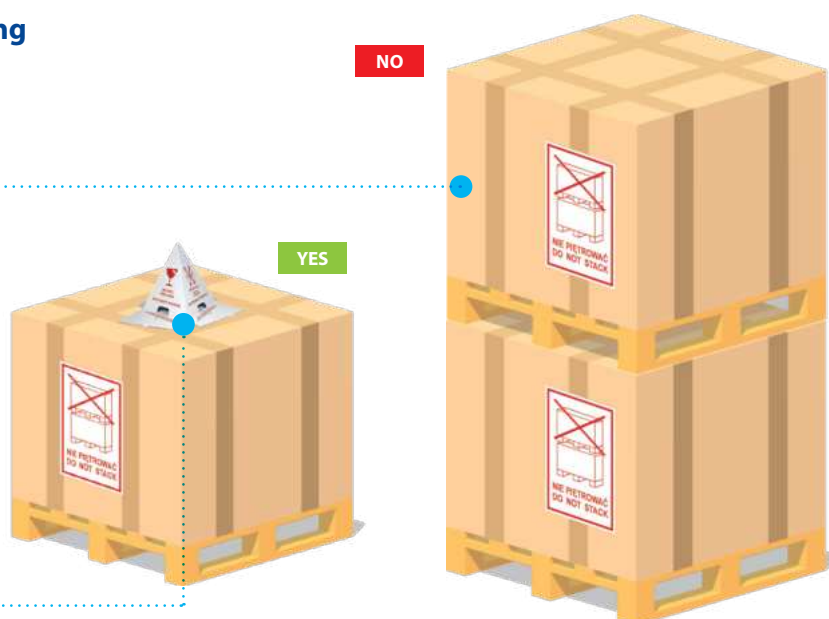
HOW TO PREPARE A PARCEL CONTAINING NUMEROUS ITEMS
IN LTL TRANSPORTATION?

RULES FOR PACKING UNUSUAL PARCELS

Sample cargo type: buckets

1. The carrier pallet is not damaged and is of good quality.
2. **There is a cardboard divider** on the pallet.
3. **A cardboard divider is necessary** at least every three layers.
4. At the very **top is a divider that prevents the buckets from moving.**
5. The goods are firmly attached to the carrier with straps.
6. In addition, the pallet is wrapped in a very good quality film and the contents do not protrude beyond the pallet outline.

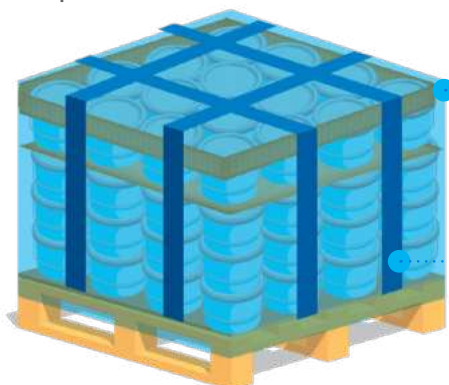
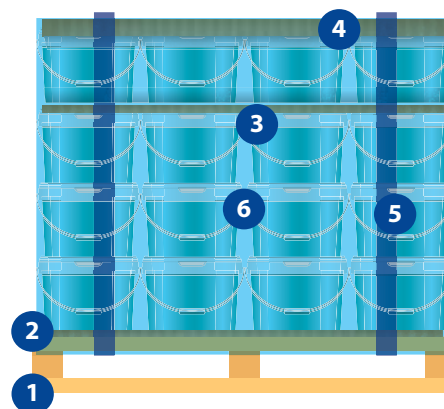

A cardboard divider that prevents the buckets from moving also protects the corners.

Plastic strap.

MARKING OF UNIT PARCELS

Warning stickers, UN number, if required:



✓ This sign should be used on two opposite sides.

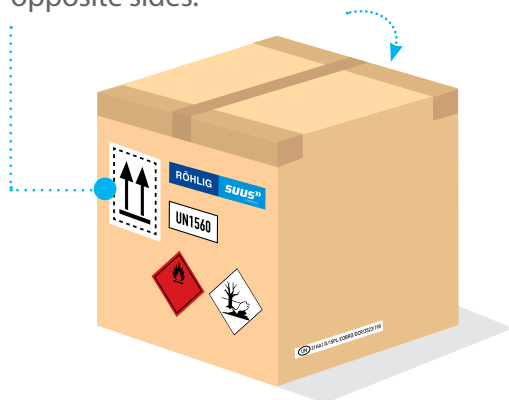

MARKINGS ON GOODS IN LIMITED QUANTITY

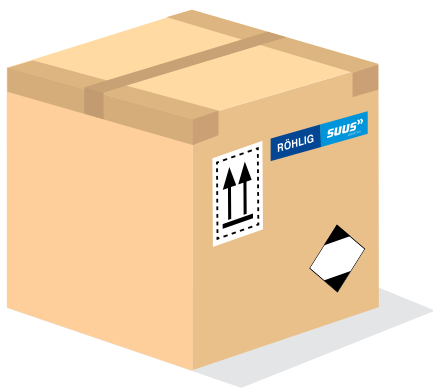

MARKING OF GOODS IN EXCEPTED QUANTITY



MARKING OF COLLECTIVE PACKAGING

✓ Use directional arrows on two opposite sides.

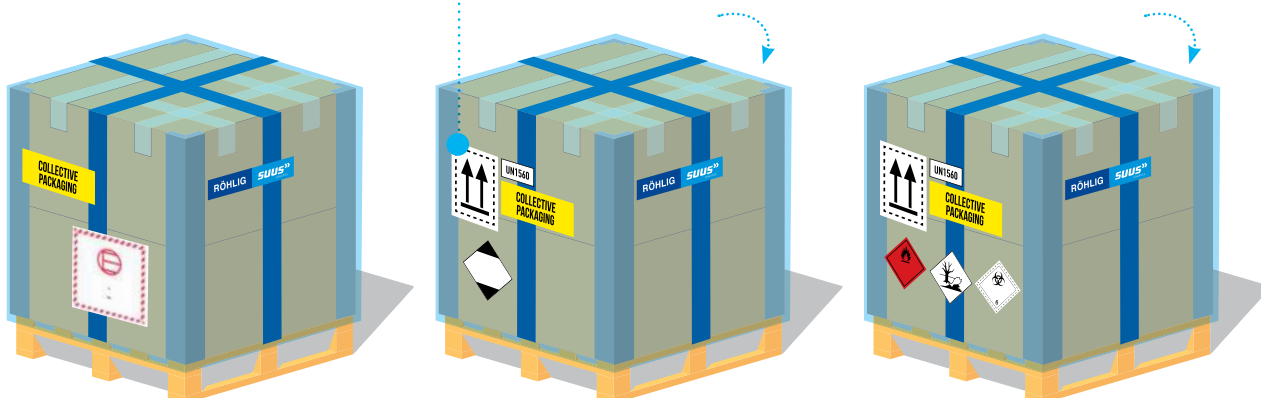

HOW TO PREPARE RETURN DOCUMENTS IN LTL TRANSPORTATION?

⚠ REMEMBER! Return documents must be placed pallet/**on the first** pallet box/roll (if there are more than one).

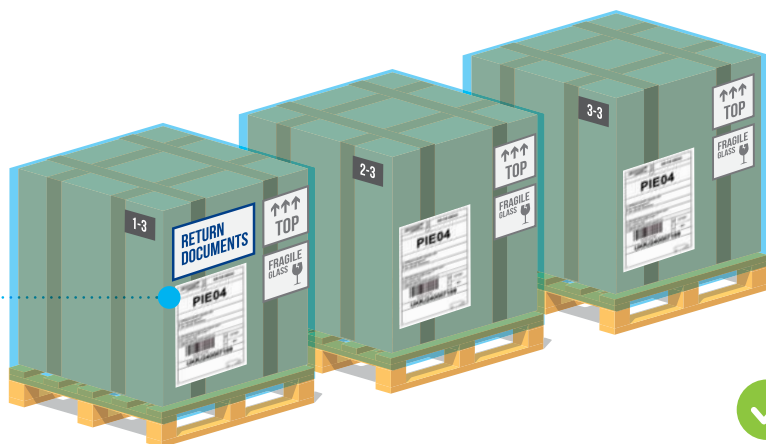

Dear Client,

If the standards above don't contain descriptions of properly protecting your products during transport please, contact us:
quality.war@suus.com.

We will answer all your questions and help you choose appropriate security measures to avoid possible complaints and enhance the satisfaction of your recipient.

We ensure that each shipment reaches its destination intact and that your satisfaction with our services is of the highest level.

